

**Hollow-Shaft
Conductive Plastic
Potentiometric
Sensors**

WAL300/305 Series



Special features

- hollow shaft
- low-cost
- 4×10^6 movements
- very high resolution – better than 0.3°

Careful selection of materials and high-quality components ensure a constant and accurate angle measurement throughout the entire service life of the sensor.

Special designs with other angular ranges are available on request.

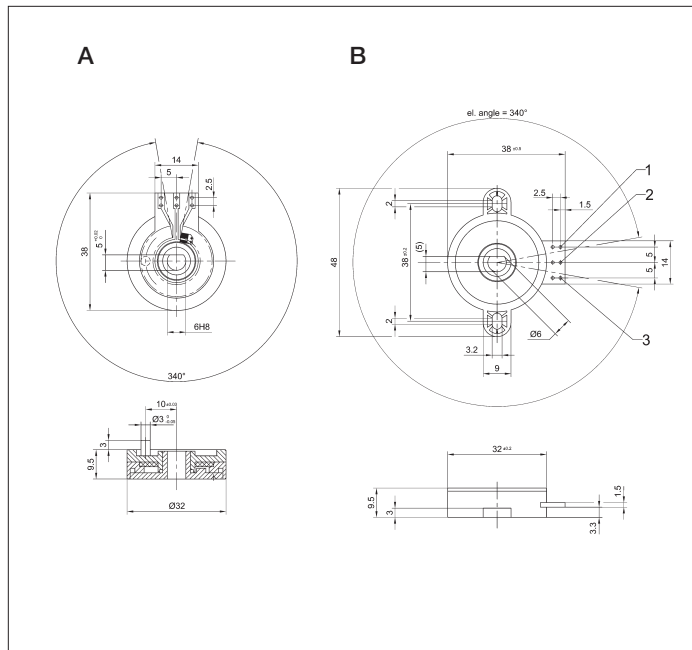

Description

Size	housing diameter 32 mm
Housing	Thermoplast
Bearings	sleeve bearings
Resistance element	conductive plastic
Wiper assembly	precious metal multi-finger wiper
Electrical connections	soldering pads

Novotechnik U.S., Inc.155 Northboro Road
Southborough, MA 01772

Phone: 508-485-2244

Fax: 508-485-2430

Email: info@novotechnik.com

Type designations	WAL300	WAL305
Mechanical Data		
Dimensions	see drawing A	see drawing B
Mechanical travel	continuous	°
Permitted shaft loading (axial and radial) static or dynamic force	1	N
Torque	≤ 1	Ncm
Maximum operational speed	120	RPM
Weight	8	g
Electrical Data		
Actual electrical travel	340	°
Resistance value	5	kΩ
Resistance tolerance	±20	%
Repeatability	0.09 (=0.3°)	%
Effective temperature coefficient of the output-to-applied voltage	5 (typical)	ppm/K
Independent linearity	±2	%
Max. permissible applied voltage	35	V
Recommended operating wiper current	≤ 1	μA
Max. wiper current in case of malfunction	5	mA
Insulation resistance (500 VDC, 1 bar, 2 s)	≥ 10,000	MΩ
Dielectric strength (AC, 50 Hz, 1 min, 1 bar)	500	V
Environmental Data		
Temperature range	-25...+75	°C
Vibration	50...500 A _{max} = 0.75 a _{max} = 2	Hz mm g
Life	4 x 10 ⁶	movements
Shock (DIN IEC 68 T2-27)	50 10	g ms
Protection class (DIN 40050)	IP 50	

Order designations

Type	Art. no.	R in kΩ
WAL300 5K0 1A	82920	5
WAL305 5K0 1A	82871	5

Order designations /**Abbreviations**

1A: soldering pads

Recommended accessories

MAP process-control indicators and display. MUP signal conditioner for standardized output signals.

Important

All values given for this series – including linearity, lifetime, micro-linearity, resistance to external disturbances and temperature coefficient in voltage dividing mode – are quoted for the device operating with the wiper voltage driving an operational amplifier working as a voltage follower where virtually no load is applied to the wiper ($I_e \leq 1 \mu\text{A}$).

Subject to changes

© August 2005

Novotechnik U.S., Inc. All rights reserved.